



CFM600S Series

Application Note V11 February 2026

600W AC-DC Power Supply with PFC CFM600S Series APPLICATION NOTE



Approved By:

Department	Approved By	Checked By	Written By
Research and Development Department	Ovid	Yang	Rong Bin
Design Quality Department	Benny	JoJo	



CFM600S Series

Application Note V11 February 2026

Content

1. INTRODUCTION	3
2. ELECTRICAL BLOCK DIAGRAM	3
3. MAIN FEATURES AND FUNCTIONS	4
3.1 <i>Operating Temperature Range</i>	4
3.2 <i>Output Protection (Over Current Protection)</i>	4
4. APPLICATIONS	4
4.1 <i>Test Set-Up</i>	4
4.2 <i>Output Ripple and Noise Measurement</i>	4
4.3 <i>Installation Instruction</i>	5
4.4 <i>External Baseplate Cooling</i>	8
4.5 <i>PS On/Off Remote Control</i>	9
4.6 <i>Power Good (PG) and Power Fail (PF)</i>	9
4.7 <i>Output Remote Sensing</i>	9
4.8 <i>EMI Test</i>	10
4.9 <i>Mating Connectors</i>	10
4.10 <i>Parallel Operation Function (Option)</i>	11
5. PACKING INFORMATION	12



CFM600S Series

Application Note V11 February 2026

1. Introduction

This application note describes the features and functions of Cincon's CFM600S series of open frame, switching AC-DC power module. These are highly efficient, reliable, compact, high power density, single output AC/DC power modules. The module is fully protected against short circuit and over-voltage conditions. Cincon's world class automated manufacturing methods, together with an extensive testing and qualification program, ensure that the CFM600S series power module is extremely reliable.

2. Electrical Block Diagram

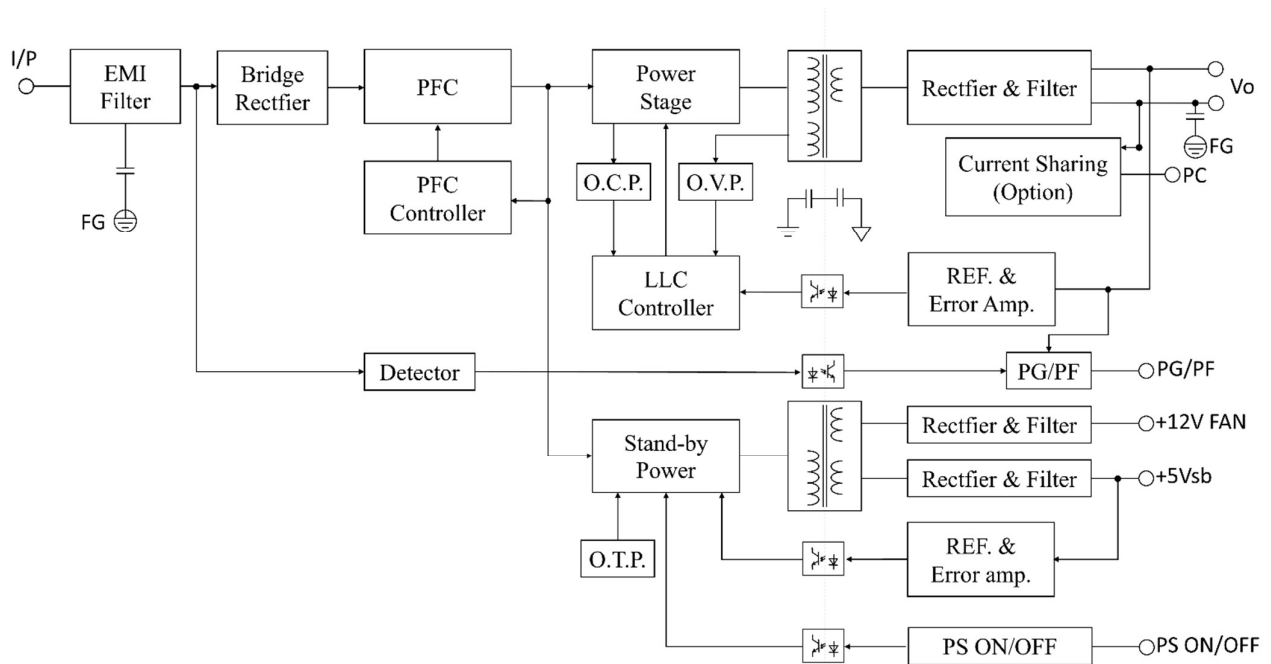



CFM600S Series

Application Note V11 February 2026

3. Main Features and Functions

3.1 Operating Temperature Range

The highly efficient design of Cincon's CFM600S series power modules has resulted in their ability to operate within ambient temperature environments from -40°C to 85°C. Due consideration must be given to the de-rating curves when ascertaining the maximum power that can be drawn from the module. The maximum power which can be drawn is influenced by a number of factors, such as:

- Input voltage range
- Permissible output load (per derating curve)
- Effective heat sinks

3.2 Output Protection (Over Current Protection)

The power modules provide full continuous short-circuit protection. The unit will auto recover once the short circuit is removed. To provide protection in a fault condition, the unit is equipped with internal over-current protection. The unit will operate normally once the fault condition is removed. The power module will go to hiccup mode if the output current is set from 120% to 190% of rated current.

4. Applications

4.1 Test Set-Up

The basic test set-up to measure parameters such as efficiency and load regulation is shown in Figure 1. When testing the Cincon's CFM600S series under any transient conditions, please ensure that the transient response of the source is sufficient to power the equipment under test. We can calculate the

- Efficiency
- Load regulation and line regulation

The value of efficiency is defined as:

$$\eta = \frac{V_o \times I_o}{P_{in}} \times 100\%$$

Where:

- V_o is output voltage
- I_o is output current
- P_{in} is input power

The value of load regulation is defined as:

$$Load\ reg. = \frac{V_{FL} - V_{NL}}{V_{NL}} \times 100\%$$

Where:

- V_{FL} is the output voltage at full load
- V_{NL} is the output voltage at 10% load

The value of line regulation is defined as:

$$Line\ reg. = \frac{V_{HL} - V_{LL}}{V_{LL}} \times 100\%$$

Where:

- V_{HL} is the output voltage of maximum input voltage at full load
- V_{LL} is the output voltage of minimum input voltage at full load

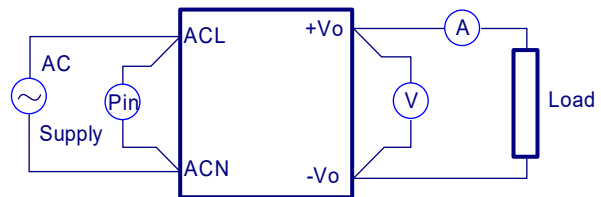

Figure 1. CFM600S Series Test Setup

4.2 Output Ripple and Noise Measurement

The test set-up for noise and ripple measurements is shown in Figure 2. Measured method:

Add a C2=0.1uF ceramic capacitor and a C1=10uF electrolytic capacitor to output at 20 MHz Band Width.

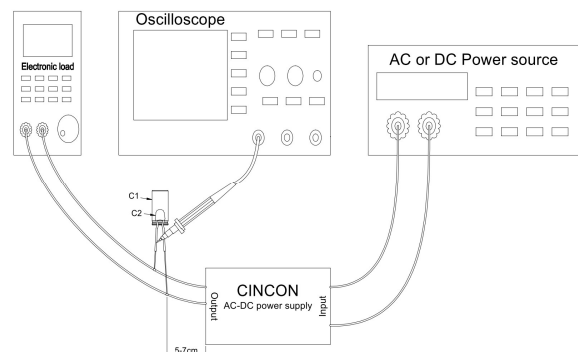

Figure 2. Output Voltage Ripple and Noise Measurement Set-Up



CFM600S Series

Application Note V11 February 2026

4.3 Installation Instruction

The CFM600S series has four 4mm diameter mounting holes. There are three type installations for CFM600S. Please use the mounting holes as follows:

Insert the spacer (4mm diameter max.) of 8mm height or more to mount the unit.

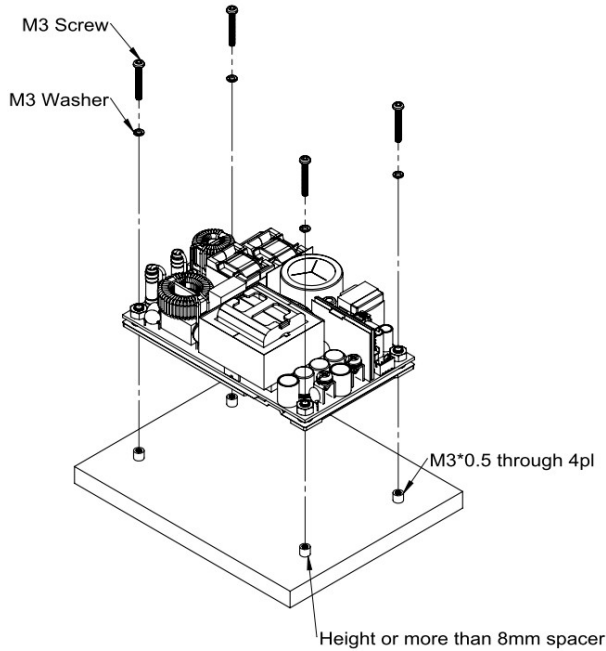

CFM600SXXX Installation Diagram

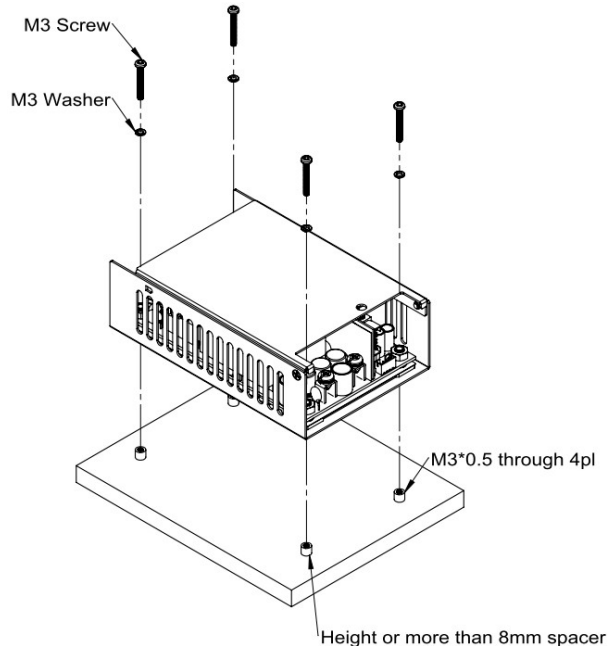

CFM600SXXXC Installation Diagram

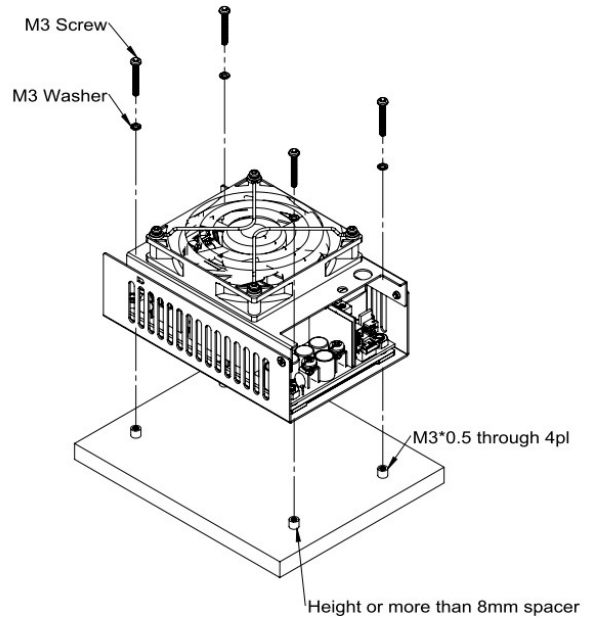

CFM600SXXXF Installation Diagram

The CFM600S series provide the baseplate cooling for customer to increasing heat dissipation. Please refer to the following figure for installation.

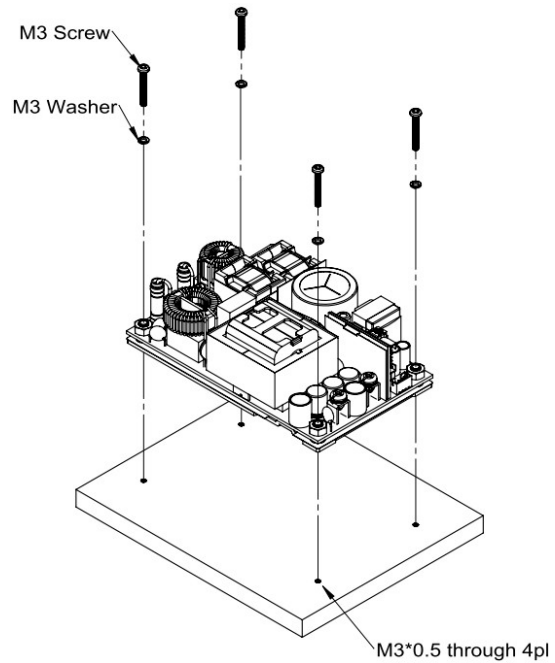

CFM600SXXX Installation Diagram



CFM600S Series

Application Note V11 February 2026

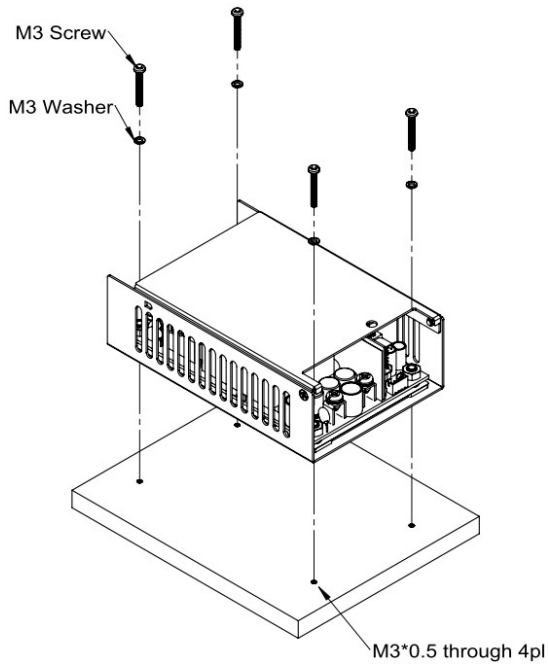

CFM600SXXX installation diagram

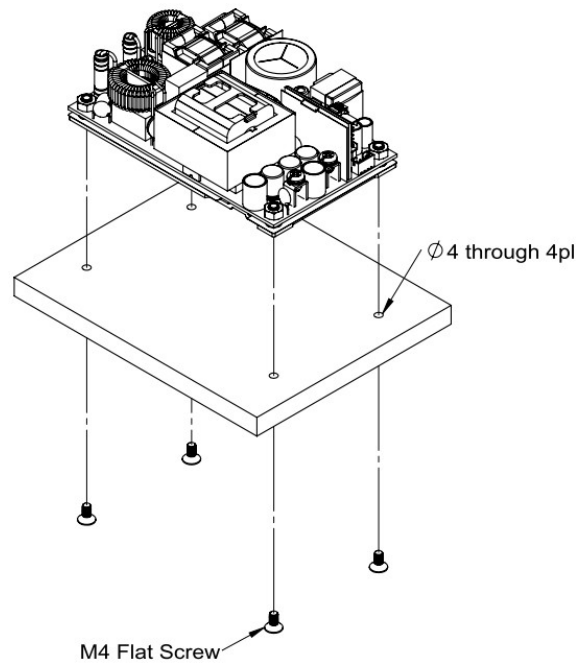

CFM600SXXX installation diagram

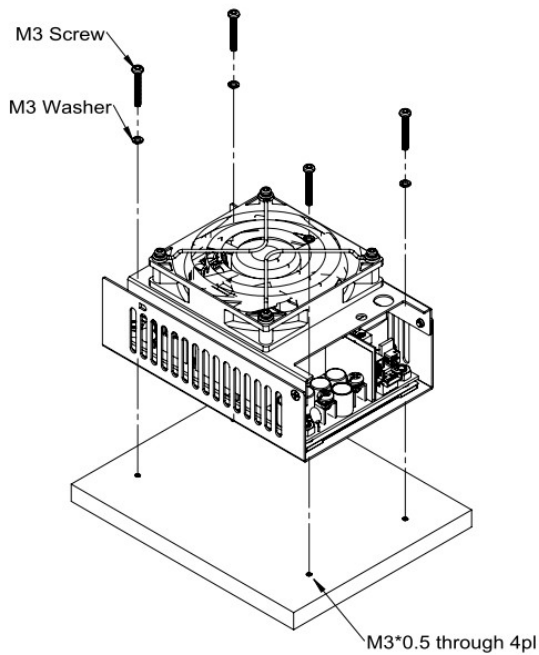

CFM600SXXXF installation diagram

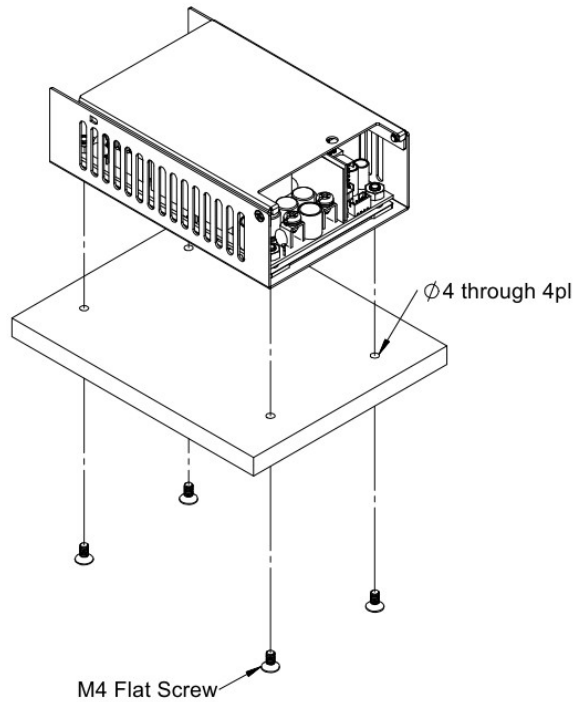

CFM600SXXXC installation diagram



CFM600S Series

Application Note V11 February 2026

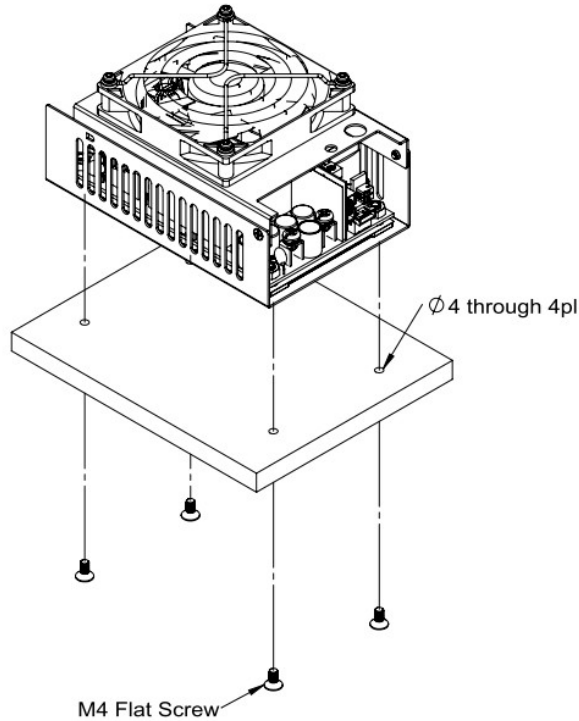

CFM600SXXXF installation diagram

Note: M3 & M4 screw head and washer diameter shall not exceed 5.5mm.

The torque of CFM600S series as follows:

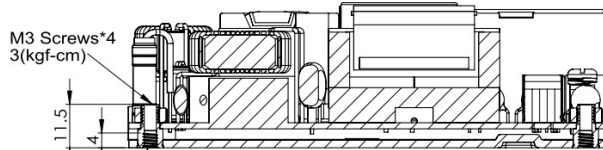

M4 Screws*4
7(kgf-cm)

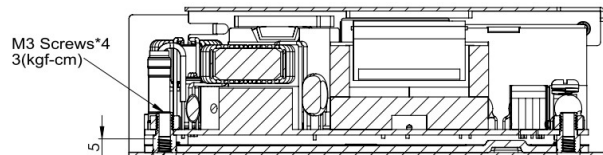

M4 Screws*4
7(kgf-cm)

The torque of M3 screws are 3kgf-cm and M4 screws are 7kgf-cm. The torque of output connectors are 7kgf-cm and the connectors mate with round terminal. The maximum outer diameter of the terminal is 8.0mm and the maximum inner diameter is 4.3mm. When locking the round terminal or Y terminal to output connectors, the terminals should not touch other parts to avoid short.

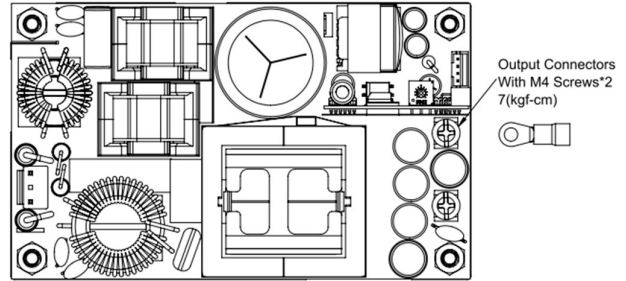

Please allow 4mm side clearance from the components and all side of the PCB. Allow 5mm clearance above the highest parts on the PCB. Be especially careful to allow 5mm between the solder side of the PCB and the mounting surface. If the clearances are not sufficient the specifications for isolation and withstand will not be valid.

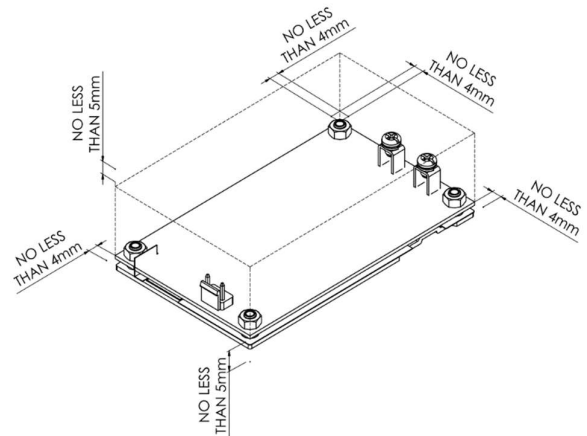



CFM600S Series

Application Note V11 February 2026

FG should be connected to the earth (ground) terminal of the apparatus. If not the conducted noise and output noise will increase.

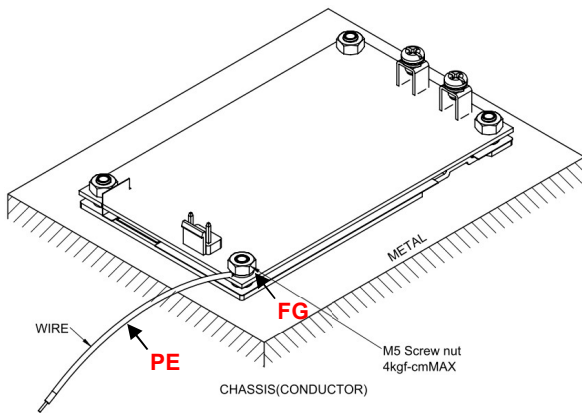
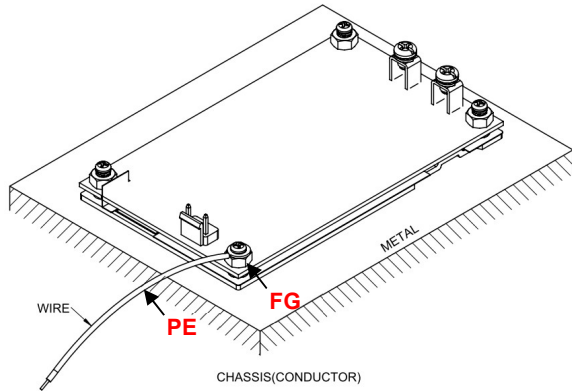

The torque of M5 screw nut is 4kgf-cm.

4.4 External Baseplate Cooling

The CFM600S series provide the baseplate cooling for customer to increasing heat dissipation. For example, adding a 430mm*430mm*2mm heatsink at the bottom of CFM600S, between the heatsink and CFM600S with thermal grease to help heating ability.

Please refer to the following figure for installation. When the CFM600S series uses an external baseplate cooling solution, it can be used at 470 ~ 600W. Please refer to the power derating curve in the specification.

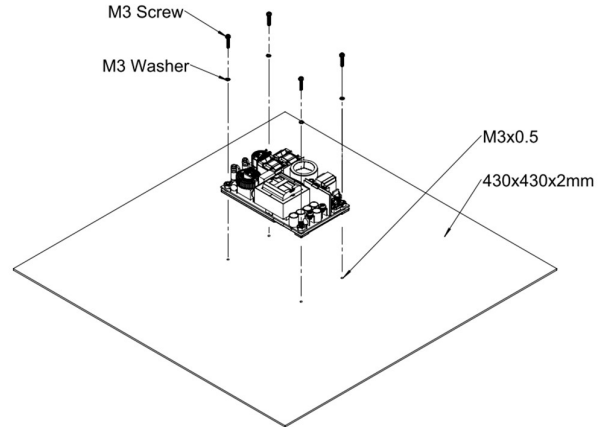

CFM600SXXX installation diagram

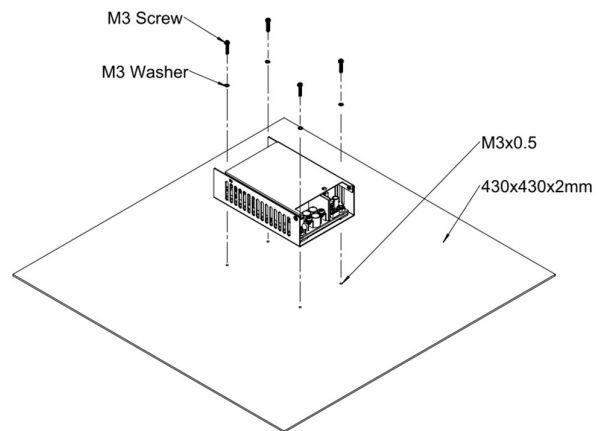

CFM600SXXXC installation diagram



CFM600S Series

Application Note V11 February 2026

4.5 PS On/Off Remote Control

The PS-ON and GND of CFM600SXXX are connected through the default Mini Jumper for normal operation of the unit.

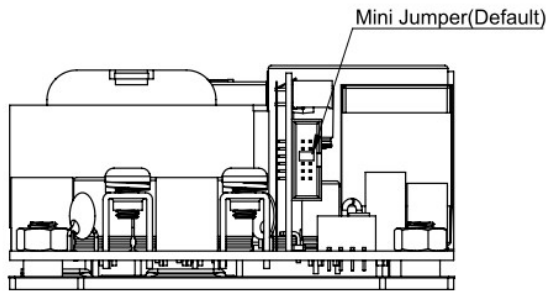

When using the PS-ON remote control function of CFM600SXXX, remove the Mini Jumper on PS-ON and GND.

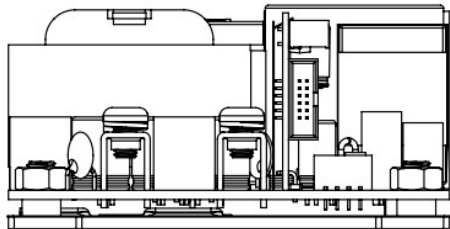

The PS-ON remote control of CFM600SXXX is provided in CN3 pin 7.

The diagram and control function are shown as follow:

Power On: $V_{PS-ON} \leq 2V$, $I_{PS-ON} \geq 10mA$ (PS-ON and GND short, $I_{PS-ON} = 10mA$ typical)

Power Off: Open circuit, $V_{PS-ON} = 4V$

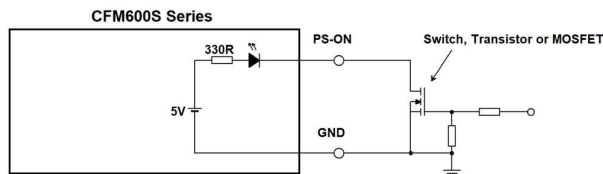

4.6 Power Good (PG) and Power Fail (PF)

The PF remote control is provided in CN3 pin9. The signal time sequence is shown as follow:

Power Good Time: $100ms \leq T_{PG} \leq 500ms$

Power Fail Time: $1ms \leq T_{PF}$ (10ms typical)

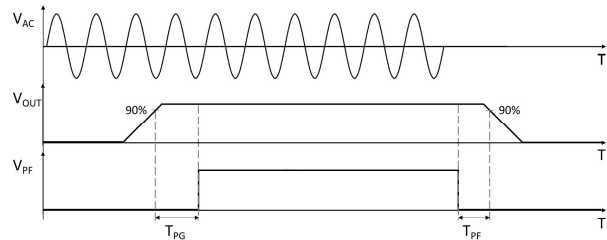

4.7 Output Remote Sensing

The CFM600S SERIES converter has the capability to remotely sense both lines of its output. This feature moves the effective output voltage regulation point from the output of the unit to the point of connection of the remote sense pins. This feature automatically adjusts the real output voltage of the CFM600S series in order to compensate for voltage drops in distribution and maintain a regulated voltage at the point of load. The remote-sense voltage range is:

$$[(+V_{out}) - (-V_{out})] - [(+Sense) - (-Sense)] \leq 5\% \text{ of } V_{o_nominal}$$

A Remote Sensing is provided in CN3. This is shown in the schematic as below.

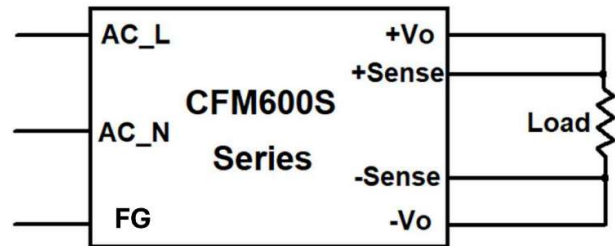



CFM600S Series

Application Note V11 February 2026

4.8 EMI Test

The CFM600S series Conductive EMI meets EN 55032, FCC Part 15 Class B when test condition is Class I.

The CFM600S series need additional the core which choose one of the following suggestions to meet EN 55032 Class B when test condition is Class II. If customers use in Class I systems, please ignore this section.

Additional Inductance related parameters:

Specification	Material	Duplex Winding /Turns	Manufacturers
74271222S	4W620	AWG16 External power cable/1T	WURTH
FC1300 FC29.7*13*25.9	N80 Ni-Zn N80-800ui	AWG16 External power cable/1T	BEECORE

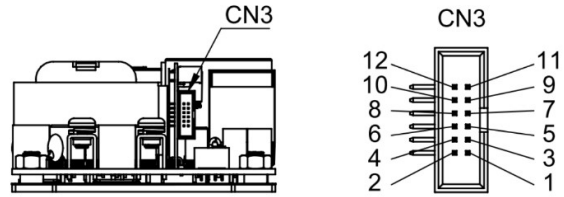
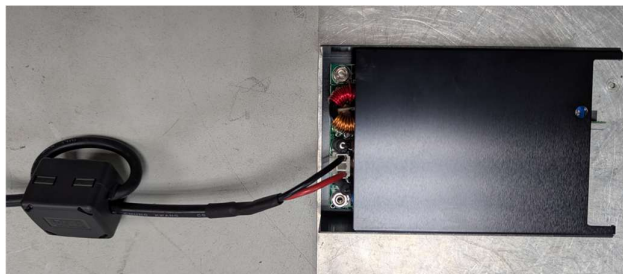
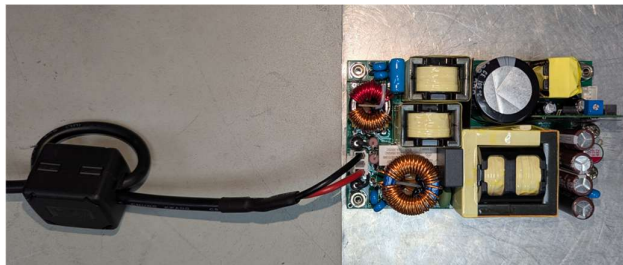

CFM600SXXXF does not have CN2, it's output connector wafer is CN9.

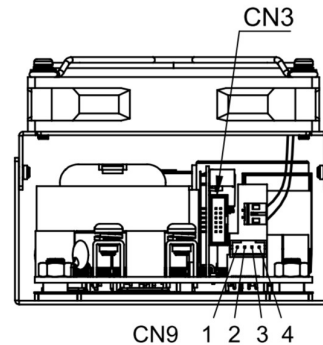

- CN1: Input connector wafer with JST VH series and mate with JST housing VHR series or equivalent. Optional Input connector wafer with LONG CHU P3161 series and mate with LONG CHU H3060 series or equivalent.
- CN2: (CN9): Output connector wafer with TAIWAN KING PIN TERMINAL P110I series and mate with JST housing PHR series or equivalent.
- CN3: Output connector wafer with B304F-12RGF-104-LH series and mate with Samtec FFSD-06-01-N series or equivalent.
- Vo+ & Vo-: Output connectors mate with round terminal and round terminal of the max outer diameter is 8.0mm, max inner diameter is 4.3mm.

DC Output Connector(CN3):Townes B304F-12RGF-104-LH or equivalent

Pin	Function	Mating Housing
1	SGND	Samtec FFSD-06-01-N or equivalent
2	NA	
3	NA	
4	NA	
5	NA	
6	NA	
7	PS ON/OFF	
8	GND	
9	PG/PF	
10	PC(Optional)	
11	Vsns-	
12	Vsns+	

4-9 Mating Connectors

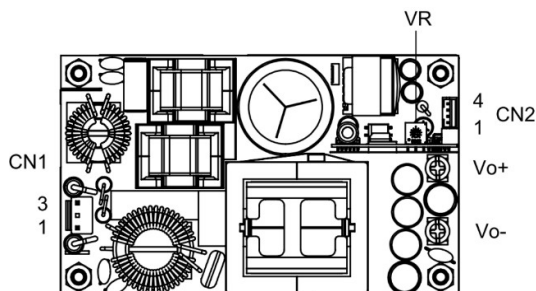



4.10 Parallel Operation Function (Option)

The parallel connection is shown in figure as below.
 The function of current sharing in parallel is connected by CN3 Pin1 & Pin8 & Pin10 (SGND & GND & PC).

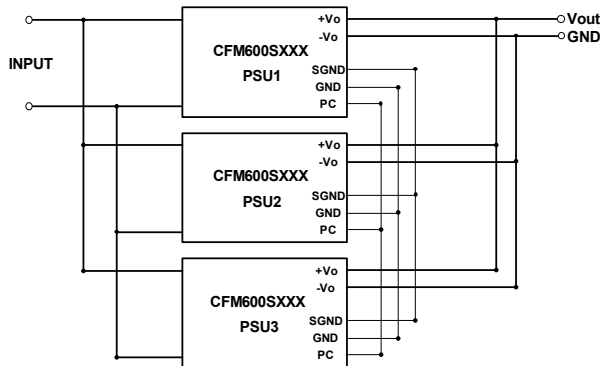

Connect the Pin7 (PS-ON) of CN3 of all PSUs to operate in parallel and start/stop at the same time.

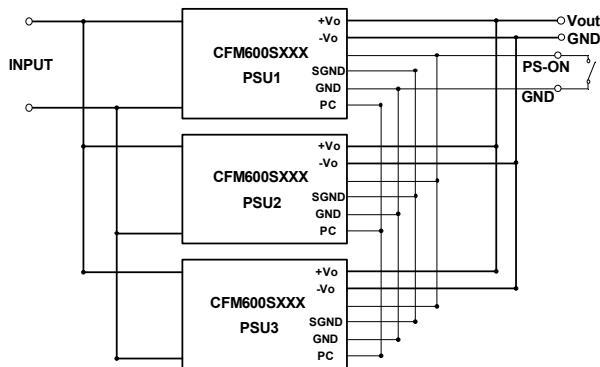

- When the PSU is operating in parallel, the remote sense feature could not be used.
- Only PSUs with the same output voltage are allowed for parallel operation and ensure the output voltage at no-load is within 0.2V.
- The maximum of total power can't exceed 90% of rated total power. The value of total output current is defined as:

$$I_{o_total} = I_{o_rated} \times N \times 0.9$$

Where:

N is number of PSU

To ensure the parallel operation function is effective, it is suggested to use the remote on/off to control the PSUs synchronously while more than two PSUs.



CFM600S Series

Application Note V11 February 2026

5. Packing Information

The packing information for CFM600SXXX is showing as follows:

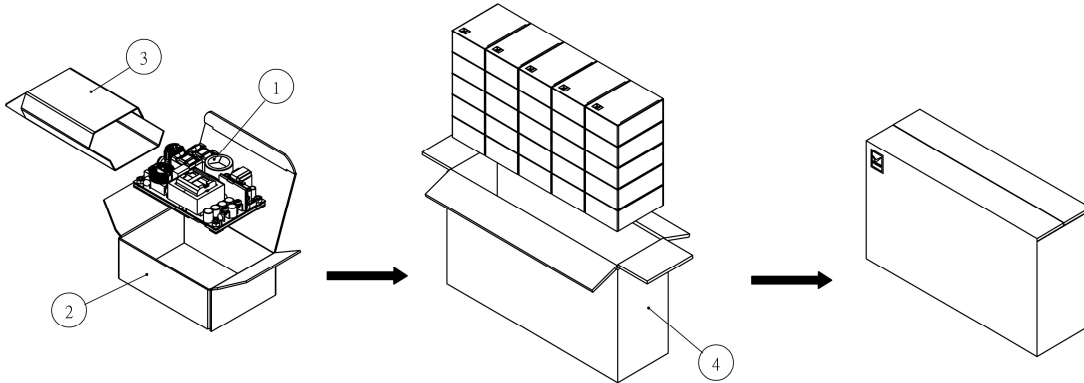

ITEM	PART NO.	NAME	OUTSIDE DIM(mm)	PCS
1		CFM600SXXX Product	127x76.2x39.1	25
2	G64205245	Inner Box	140x100x55	25
3	G64F00005	Antistatic Bag	(110+60)x165	25
4	G64112325	No.146 Cardboard Box	525x155x300	1

Each Box Packaging 25 PCS Products
Gross weight Ref. 14.5 Kg
Net weight Ref. 13 Kg

The packing information for CFM600SXXXC is showing as follows:

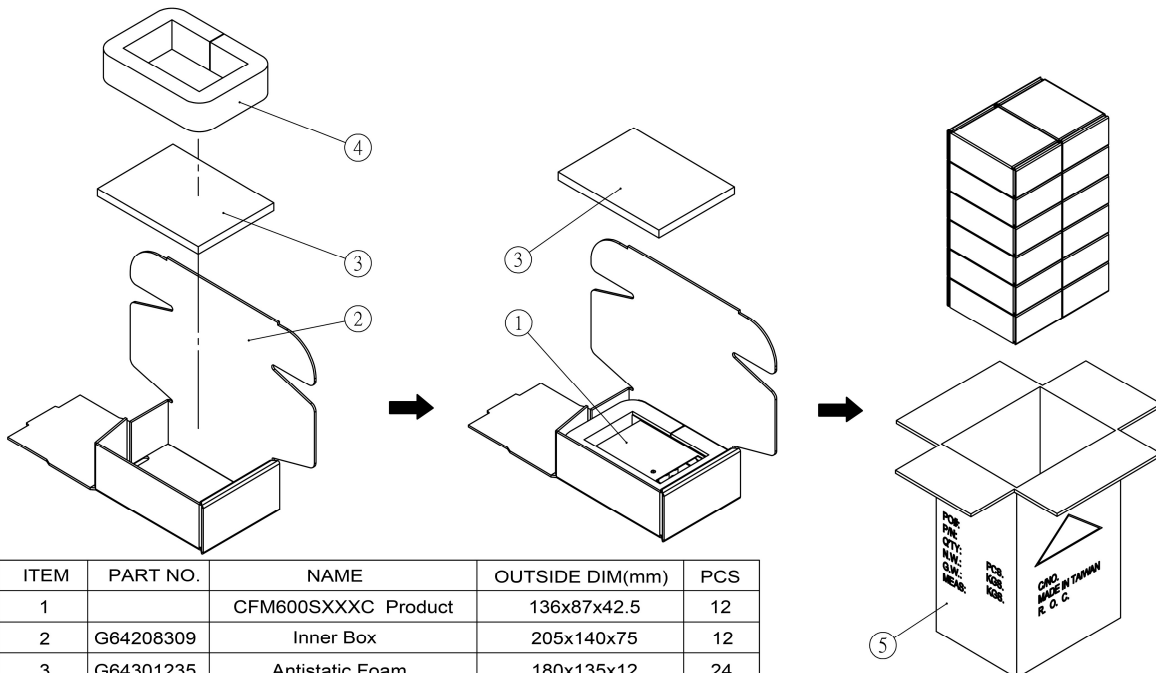

ITEM	PART NO.	NAME	OUTSIDE DIM(mm)	PCS
1		CFM600SXXXC Product	136x87x42.5	12
2	G64208309	Inner Box	205x140x75	12
3	G64301235	Antistatic Foam	180x135x12	24
4	G64301236	Antistatic Foam	530x45x25	12
5	G64100141	No.47 Cardboard Box	309.1x239.4x475.7	1

Each Box Packaging 12 PCS Products
Gross weight Ref. 10 Kg
Net weight Ref. 7.7 Kg



CFM600S Series

Application Note V11 February 2026

The packing information for CFM600SXXXF is showing as follows:

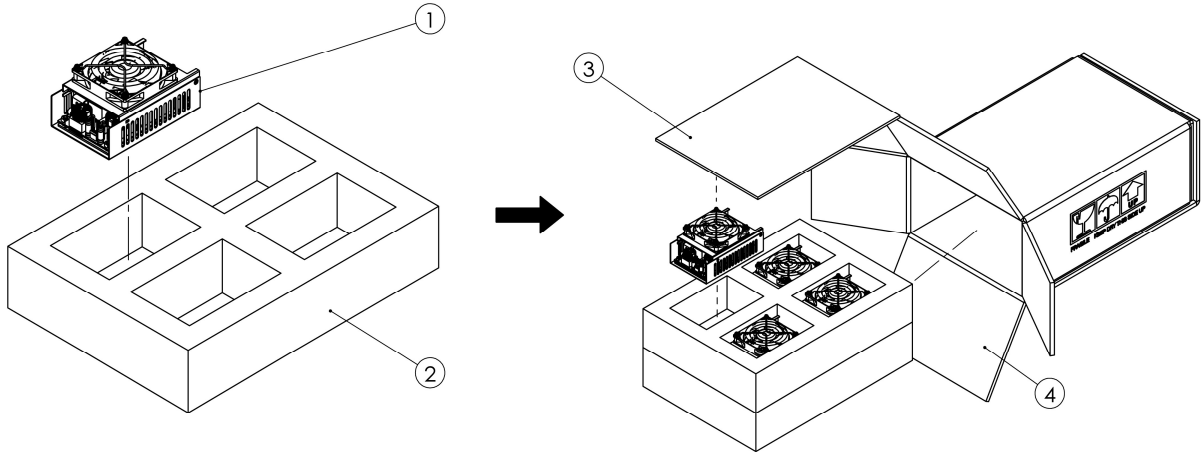

ITEM	PART NO.	NAME	OUTSIDE DIM(mm)	PCS
1	-	CFM600SXXXF Product	136x87x68.1	8
2	G64301273	Antistatic Foma	375x270x80	2
3	G64301335	Antistatic Foma	340x245x5	1
4	G64112270	No.95 Cardboard Box	390.9x284.8x175.7	1

Each Box Packaging 8 PCS Products
Gross weight Ref. 6.5 Kg
Net weight Ref. 5.7 Kg

Headquarters:

14F, No.306, Sec.4, Hsin Yi Rd.
Taipei, Taiwan
Tel: 886-2-27086210
Fax: 886-2-27029852
E-mail: sales@cincon.com.tw
Web Site: <https://www.cincon.com>

CINCON ELECTRONICS CO., LTD.

Factory:

No. 8-1, Fu Kung Rd.
Fu Hsing Industrial Park
Fu Hsing Hsiang,
Chang Hua Hsien, Taiwan
Tel: 886-4-7690261
Fax: 886-4-7698031

Cincon North America:

1655 Mesa Verde Ave. Ste 180
Ventura, CA 93003
Tel: 805-639-3350
Fax: 805-639-4101
E-mail: info@cincon.com